

INDEXABLE CHAMFERING CUTTER

Max. 30mm Blade Length!

- 30mm. blade length and originally designed breaker ensured maximum 30mm. Chamfering process without chattering.
- Line up 5°~85° Angle process are ensured.

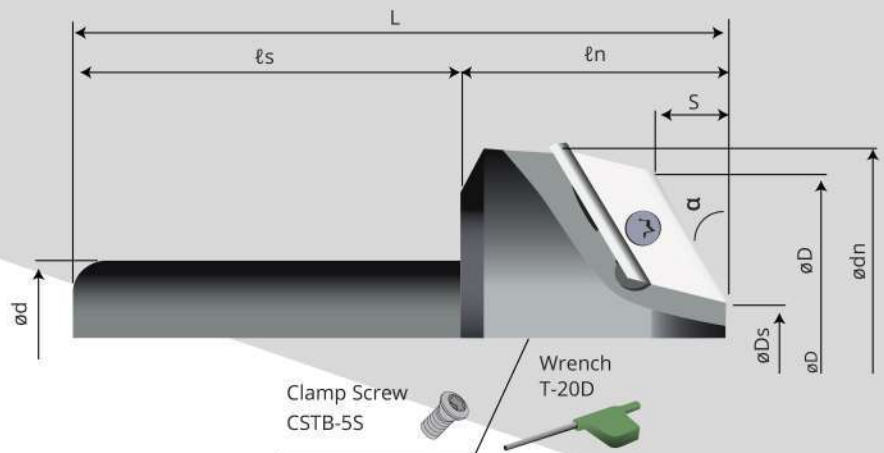

Processing Example

[C20 Chamfering]

- Body : ECC455715
- Insert: XCET310404 SJ330

- Material SUS304
- Rotation Speed 800r.p.m.
- Table feed 150mm/min.
- Cutting Depth C20
- Cutting Oil None



Result

Good! By one pass process, C20 Chamfer has been successfully made without chattering.

Corner Chamfering

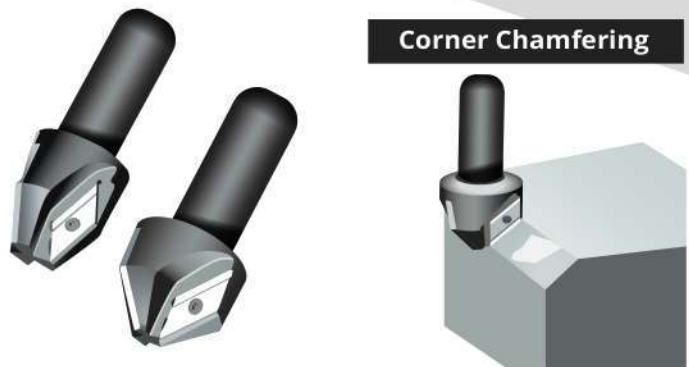

Body

Model N°	BLADES	Dimensions (mm)								α
		ϕD	ϕD_s	ϕd	ϕd_n	L	l_s	l_n	S	
ECC057415	3	74.8	15.0	32	102.8	135	80	55	2.6	5°
ECC107415	3	74.5	15.0	32	99.5	135	80	55	5.2	10°
ECC157315	3	73.3	15.0	32	95.2	135	80	55	7.8	15°
ECC207115	3	71.8	15.0	32	90.3	135	80	55	10.3	20°
ECC256915	3	69.8	15.0	32	84.9	135	80	55	12.8	25°
ECC306715	3	67.4	15.0	32	79.0	135	80	55	15.1	30°
ECC356415	3	64.6	15.0	32	72.8	135	80	55	17.4	35°
ECC406115	3	61.4	15.0	32	66.3	135	80	55	19.5	40°
ECC455715	3	57.9	15.0	32		135	80	55	21.4	45°
ECC505718	3	57.0	18.0	32		135	80	55	23.2	50°
ECC555622	3	56.8	22.0	32		135	80	55	24.8	55°
ECC605424	3	54.3	24.0	32		135	80	55	26.3	60°
ECC655328	3	53.6	28.0	32		145	80	65	27.5	65°
ECC705232	3	52.8	32.0	32		145	80	65	28.5	70°
ECC755035	3	50.7	35.0	32		145	80	65	29.3	75°
ECC804838	3	48.5	38.0	32		145	80	65	29.9	80°
ECC854742	3	47.3	42.0	32		145	80	65	30.3	85°

- Insert is not equipped as standard accessory
- Clamp screw and wrench are supplied as standard accessory.

42,16€ plaquita

195€ /unidad

INDEXABLE CHAMFERING CUTTER

INSERT: XCET31

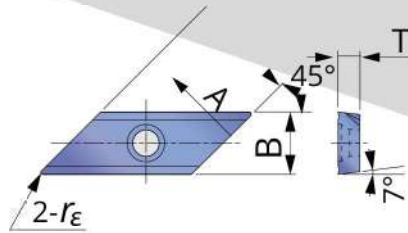

P	Steel	★									
M	Stainless	★									
	Cast iron	★									
N	Non-ferrous										
S	Superalloys										
H	Hard materials										

★ : First choice

Designation	rE	Coating	Cermet	Un-coated	A	B	T
		SJ330					
XCET310404	0.4	●			22	12.7	4.5

● : Line-up

CUTTING CONDITIONS

ISO	Workpiece material	Grade	N° of revolution n (min ⁻¹)	Feed per tooth: fz (mm/t)
P	Carbon steels C55, etc. Alloy steels 42CrMo4, etc. < 300 HB	SJ330	1000 - 3000 - 7000	0.1 - 0.25
	Die steels X40CrMoV5-1, etc. < 300 HB	SJ330	700 - 2000 - 4900	0.1 - 0.25
	Die steels X40CrMoV5-1, etc. < 300 HB	SJ330	1000 - 3000 - 7000	0.1 - 0.2
M	Stainless steels X5CrNi18-10, etc. < 250 HB	SJ330	1000 - 3000 - 7000	0.1 - 0.25
K	Cast Irons 250, etc.	SJ330	1000 - 3000 - 7000	0.1 - 0.25

Your specialist dealer

SIJALÓN

Suministros Industriales

T: +34 976 109 870

M: sijalon@sijalon.net

www.sijalon.com

Sijalon
Suministros industriales